



14+



3



1,8m



1 = 3,66m

2 = 0,7m

3 = 1,92m



Discapacidad motriz  
Discapacidad sensorial  
Discapacidad mental

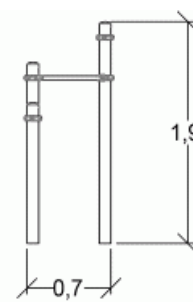
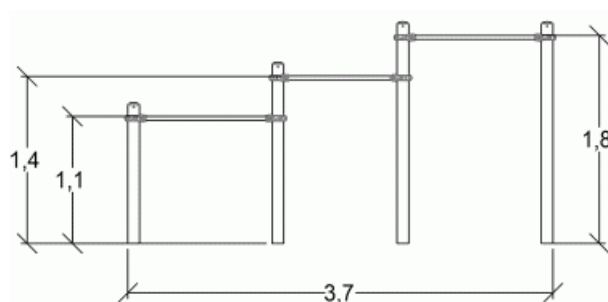

## Funciones Lúdicas : 3

colgarse



x3

## Elementos constituyentes

① Horizontal bar L:1.25m

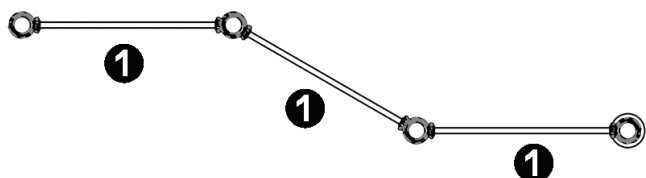

## Instalación del equipamiento

Zona de impacto: Superficie de suelo mínima requerida

— Zona de impacto  
- - - Espacio libre

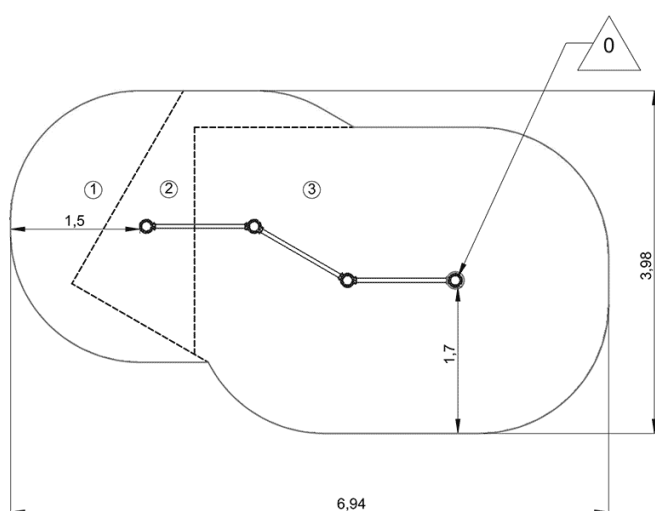

1	1,1m	4m <sup>2</sup>
2	1,45m	3m <sup>2</sup>
3	1,8m	16m <sup>2</sup>



2



02h00



0.8m<sup>3</sup>



23m<sup>2</sup>



86kg



19kg

EN

16 630