



0.5+



12



1m



1 = 2,93m  
2 = 2,24m  
3 = 2,12m



Discapacidad motriz  
Discapacidad sensorial  
Discapacidad mental

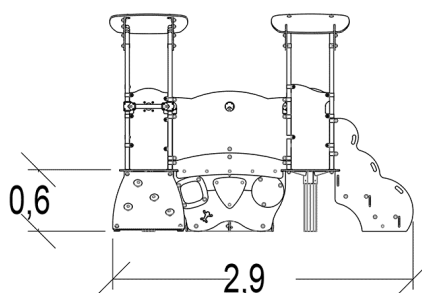
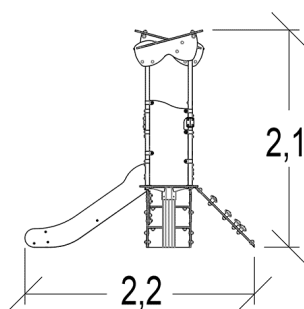

**Funciones Lúdicas : 19**

imaginar	deslizarse	encontrarse	manipular	trepar	ocultarse	refugiarse	estimulación táctil
x2	x1	x2	x1	x1	x3	x2	x1
estimulación visual	trepar	atravesar					
x3	x2	x1					

## Elementos constituyentes

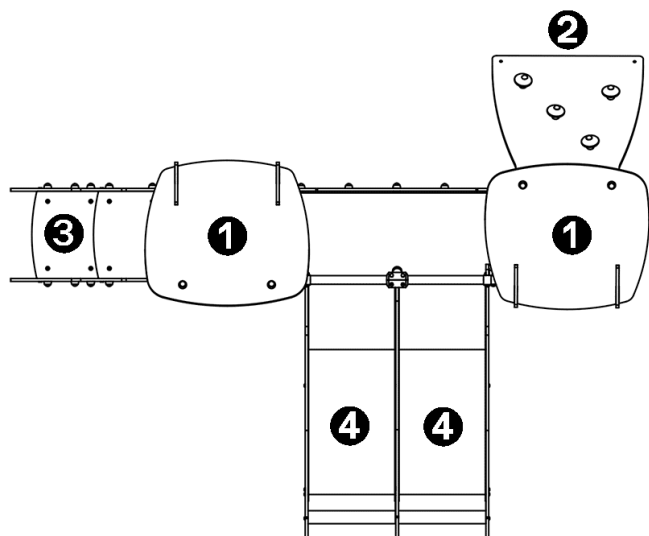

- 1 Plataforma Al.: 0,6 m
- 2 Superficie inclinada
- 3 Baby access steps
- 4 Double slide

## Instalación del equipamiento

Zona de impacto: Superficie de suelo mínima requerida

- Zona de impacto
- Espacio libre

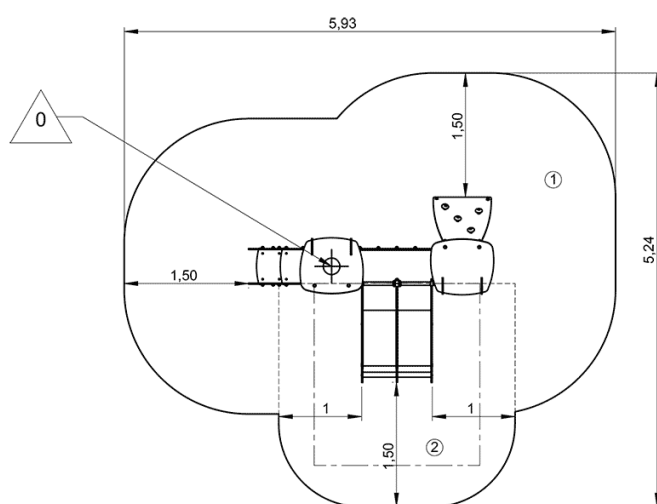

1	0,6m	16,5m <sup>2</sup>
2	1m	7,5m <sup>2</sup>



2



05h00



0.3m<sup>3</sup>



24m<sup>2</sup>



264kg



22kg

EN

1176