



3+



28



2,6m



1 = 8,23m  
2 = 4,05m  
3 = 2,7m



Discapacidad motriz  
Discapacidad sensorial  
Discapacidad mental

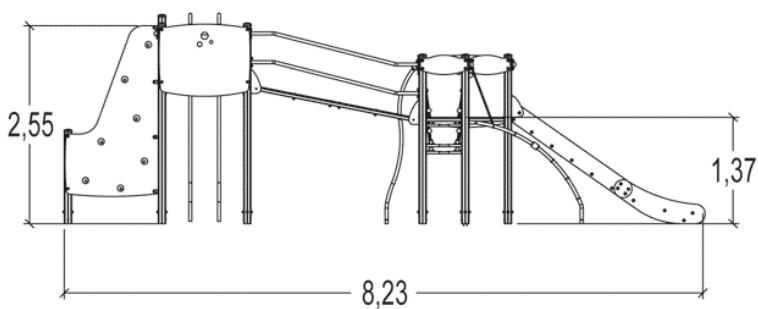
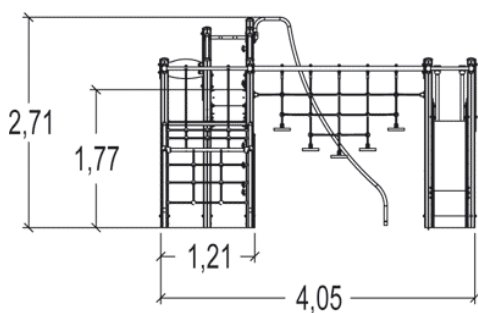

Funciones Lúdicas : 11

escalar



x1

deslizarse



x2

encontrarse



x3

equilibrio



x1

trepar



x2

atravesar



x2

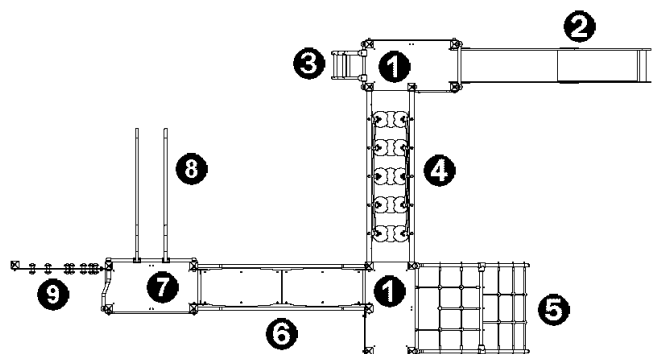

## Elementos constituyentes



- 1 Plataforma rectangular
- 2 Tobogán
- 3 Escalerilla curvada
- 4 Peldaños flotantes
- 5 Red de trepa curvada
- 6 Puente inclinado
- 7 Plataforma rectangular
- 8 Tobogán Speed
- 9 Pared de trepa

## Instalación del equipamiento

Zona de impacto: Superficie de suelo mínima requerida

-  Zona de impacto
-  Espacio libre

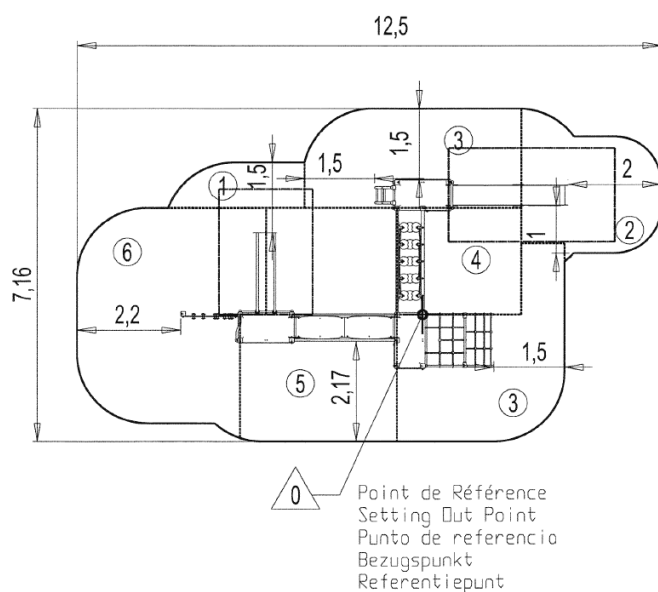

1	0,6m	2,5m <sup>2</sup>
2	1m	7,5m <sup>2</sup>
3	1,37m	20,5m <sup>2</sup>
4	2,1m	6,5m <sup>2</sup>
5	2,5m	16m <sup>2</sup>
6	2,6m	16,5m <sup>2</sup>



2

20h00

0.6m<sup>3</sup>

69.5m<sup>2</sup>

646kg

46kg

EN

1176