



3+



23



2,6m



1 = 5,57m  
2 = 4,35m  
3 = 3,1m



Discapacidad motriz  
Discapacidad sensorial  
Discapacidad mental

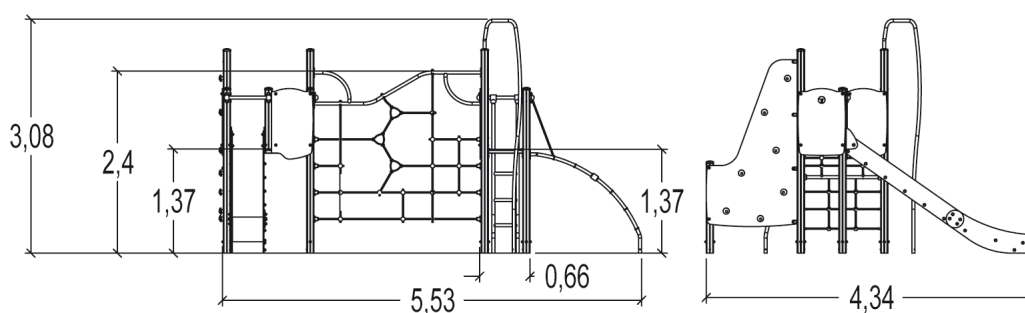

## Funciones Lúdicas : 8

escalar



x1

deslizarse



x2

encontrarse



x2

trepar



x3

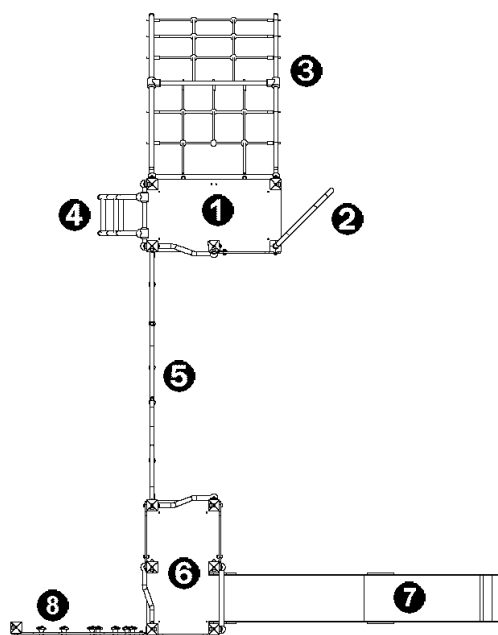

## Elementos constituyentes



- 1 Plataforma rectangular
- 2 Barra de bomberos
- 3 Red de trepa curvada
- 4 Escalerilla curvada
- 5 Red de trepa
- 6 Tobogán
- 7 Pared de trepa

## Instalación del equipamiento

Zona de impacto: Superficie de suelo mínima requerida

-  Zona de impacto
-  Espacio libre

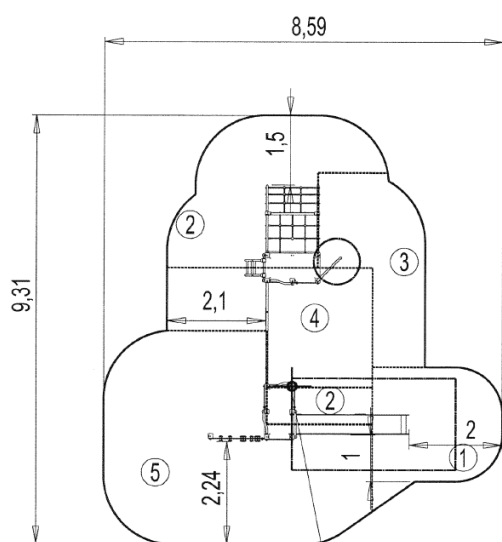

Point de Référence  
Setting Out Point  
Punto de referencia  
Bezugspunkt  
Referentiepunt



1	1m	7m <sup>2</sup>
2	1,37m	12,5m <sup>2</sup>
3	2m	7m <sup>2</sup>
4	2,4m	9m <sup>2</sup>
5	2,6m	21m <sup>2</sup>



2



18h00



0.5m<sup>3</sup>



56.5m<sup>2</sup>



466kg



46kg

