



0.5+



12



1m



1 = 2,48m
2 = 2,15m
3 = 2,12m



Discapacidad motriz
Discapacidad sensorial
Discapacidad mental

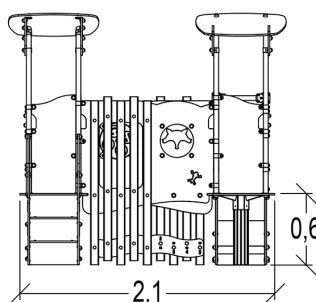
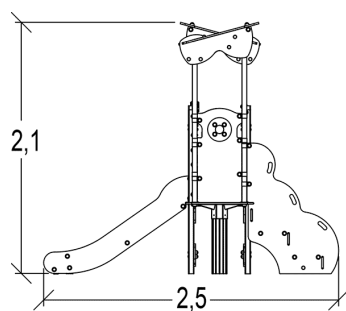

Funciones Lúdicas : 20

imaginar	deslizarse	encontrarse	manipular	trepar	ocultarse	refugiarse	reflexionar
x3	x1	x2	x1	x1	x3	x2	x1
estimulación táctil	estimulación visual	trepar	atravesar				
x1	x3	x1	x1				

Elementos constituyentes

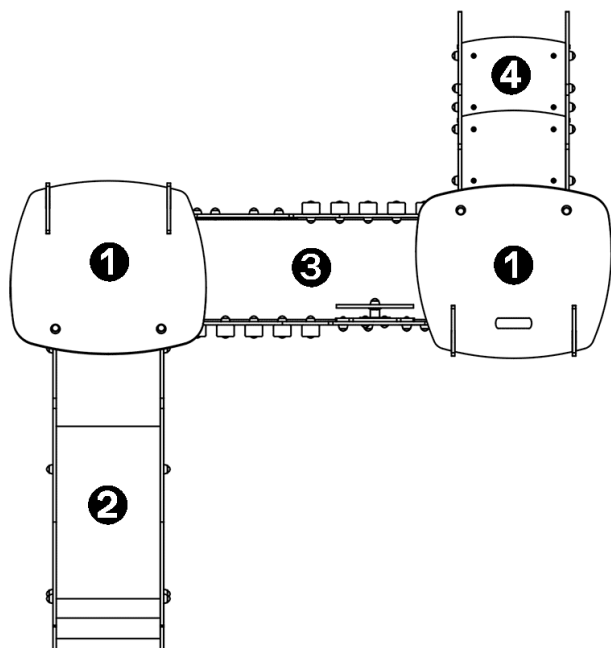

- 1 Plataforma Al.: 0,6 m
- 2 Tobogán Al.: 0,6 m
- 3 "Connecting gangway with wooden fencing"
- 4 Baby access steps

Instalación del equipamiento

Zona de impacto: Superficie de suelo mínima requerida

- Zona de impacto
- Espacio libre

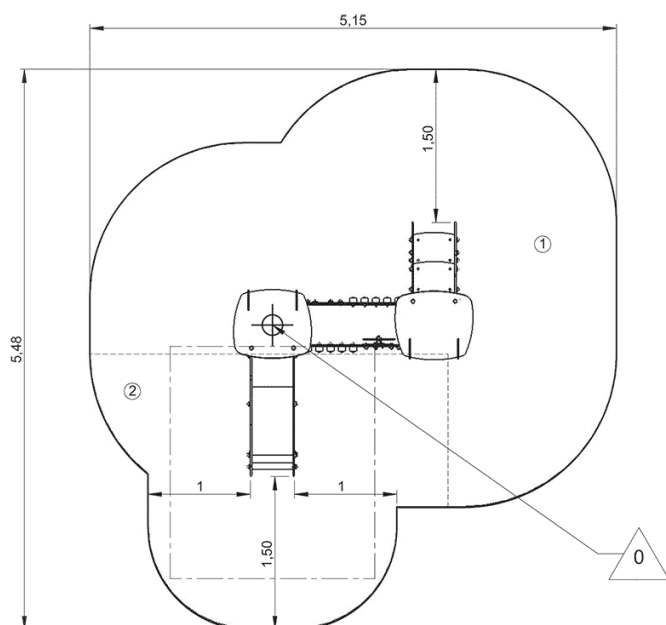

1	0,6m	14m ²
2	1m	7,5m ²



2

03h30

0.16m³

21.5m²

233kg

22kg

EN

1176